

REV	DESCRIPTION	BY	DATE
-	-	-	-

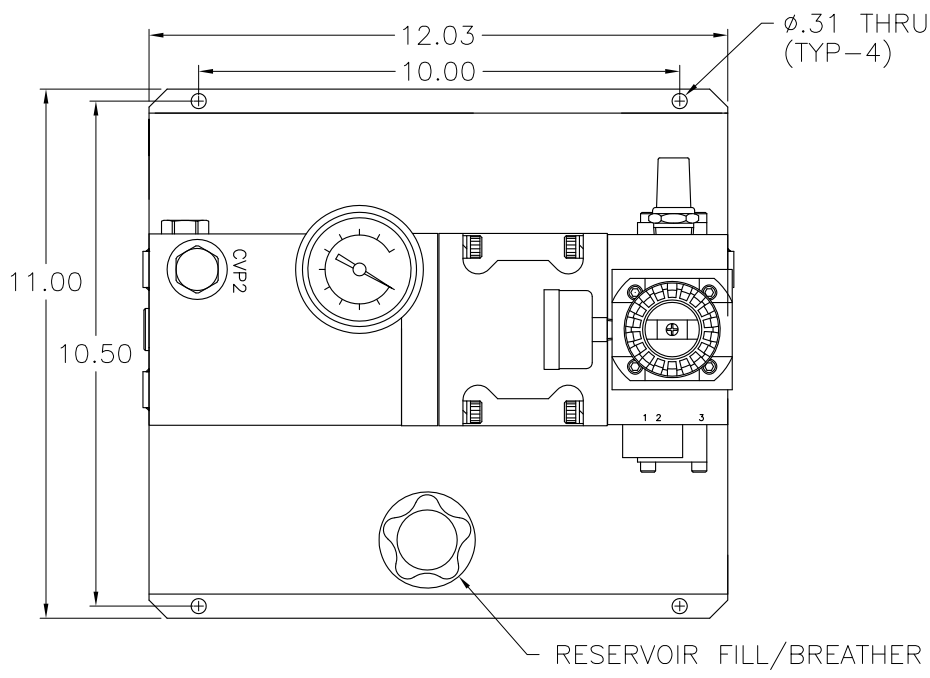

RESERVOIR	H	h
1 GAL	12.6	3.25
2 GAL	14.6	5.25
5 GAL	20.6	11.25

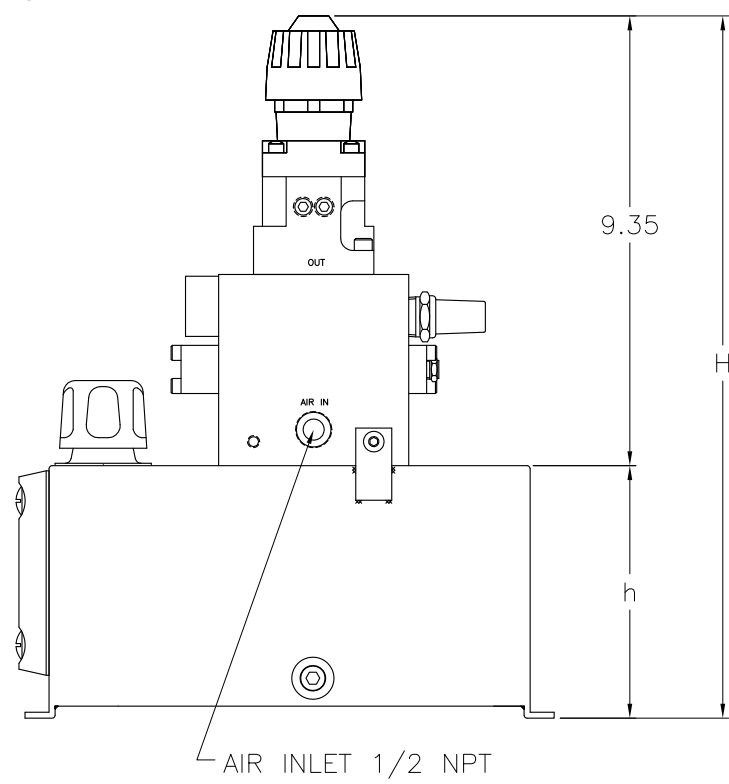
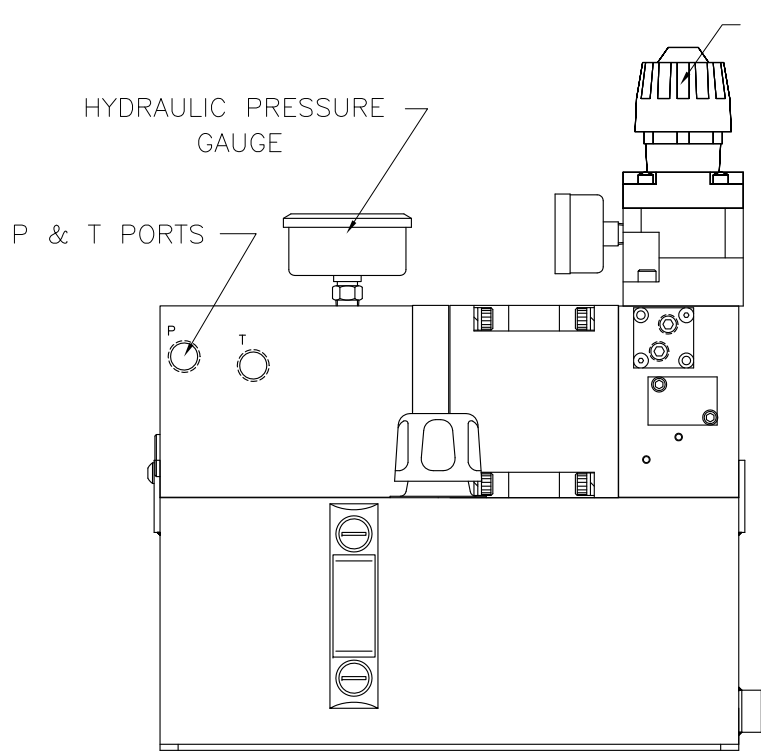

0 1 2 3 4
INCHES ON ORIGINAL DWG

		INTERFACE DEVICES, INC. 230 DEPOT ROAD MILFORD, CT 06460	
SCALE: NONE	TITLE: GENERAL ARRANGEMENT,	Exxx/xx-RGPM-xGA-00000	
DWG BY: WNI	REF:		
DATE: 1/31/00	REF:		
SHT: 1 OF: 1	DWG NO: GA-E-XGA-00000	REV:	